



Air-cooled chiller and Air-cooled  
Modular Type chiller

[Your satisfaction is always our cherished desire!]



AirTrojan International Co., Ltd.

<http://www.airtrojan.com>

AIRTROJAN-2008-03



The models and specifications listed in this catalog are subject to change without prior notification due to product improvement.

## Air-cooled chiller

### Model Code Indication

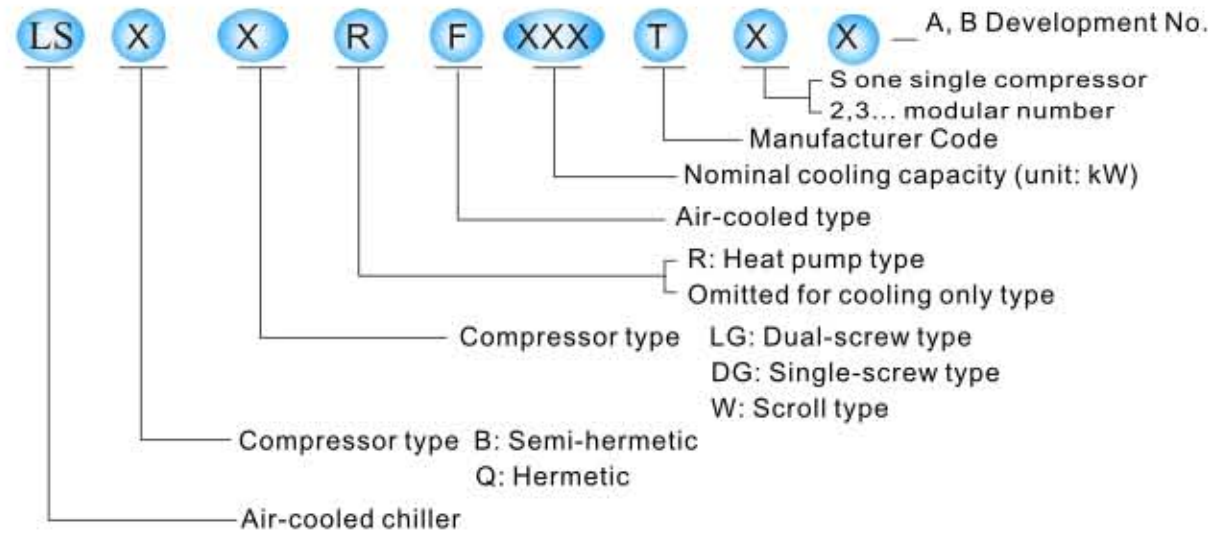

### Scroll compressor series



**Feature 1: Super slim, space-saving**

Super slim shape saves installation space, solve the problem of hanging split type air conditioners' outdoor units everywhere. Use fan coil units as terminal equipments to match your high-class decoration. Also won't have to hang indoor units everywhere any more.



**Feature 2: High efficiency and low noise**

Reliable and low noise. High heat exchange efficiency. The operating lifespan is 15~20 years, double than household air conditioners.



**Feature 3: Wide range of cooling capacity**

The cooling capacity: TB series: 25 kW-47 kW, TA series: 60kW,90kW,120kW,this capacity range is especially suitable for villas, apartments, offices and commercial buildings.



**Feature 4: Intelligent control, trouble free**

On/off, operation/malfunction alarm settlement is available. Also it will show the failure code. By automatic cooling capacity adjustment, inlet/outlet water temperature display, automatic protection against voltage fluctuation, control separate region's room temperature independently is possible. These functions let you control and adjust each room's temperature separately by actual load and solve total on or off problem so that save energy.



**Feature 5: Fresh air system is available**

Introduce fresh air to improve air quality and avoid diseases due to the use of air conditioners.



**Feature 6: Wide temperature range**

The operation range is wide and it can run under the ambient temperature form -10°C to 50°C.



**Feature 7: World famous brand accessories**

Equipped with world famous brand high efficiency scroll compressors. Use imported high efficiency water pumps (some models). Easy operation, low investment. Use imported plate type heat exchanger.



### Screw compressor series



#### Introduction:

AIRTROJAN air-cooled screw type chillers equip with world famous brand semi-hermetic dual-screw type compressors and superior quality electrical components. They have advantages such as compact structure, reliable control, low running cost, convenient installation and so on. Heating and cooling modes are both available, so it can meet the customers' requirement of cooling in summer, heating in winter. The products are widely used in shopping malls, hotels, office building, business centers and so on as central air-conditioning system. They also can meet the processing technical requirements in light spin and weave industry, chemistry industry, metallurgy industry, pharmacy, electric power mechanical industries... etc.

#### Operating range

Type		The ambient temperature °C	Water outlet temperature °C
Heat pump	Cooling	15-48	5-15
	Heating	-10-21	40-50
Cooling only type	Cooling	15-48	5-15



## Product features

### Screw compressor series

#### Product features

##### 1. Energy-saving:

Screw chillers are excellently designed and have optimal configuration. Each compressor has four-stage (25%-50%-75%-100%) capacity modulations, multi-compress system has much more capacity modulation ratios! Thus when the machine is running under partial load, it can save energy remarkably.

##### 2. High efficiency:

Equips with world famous brand compressors and the system was designed and regulated to optimum state. The electric controllers passed strict reliability tests so that ensure the machines will have excellent efficiency under both full and partial load working conditions.

##### 3. High reliability:

All the components equipped are excellent quality and tested strictly ; the compressor passes full load testing to make sure the chiller will run with high reliability.

##### 4. Long life span:

Reliable motor cooling and refrigerating system oil return techniques can provide moderate running conditions for the compressors thus prolong the lifespan tremendously.

##### 5. Easy installation:

The cooled (heated) resource of machine is air, so it does not need the huge water cooling system. Meanwhile, the units can be combined together according to the real demands of the project.

##### 6. Easy operation:

The unit uses multi-lingual LCD control panel, easy to operate and support control/protect online.

##### 7. Multiple functions:

With complete functions of safety and protection devices, it can ensure the machine runs stably. Meanwhile, the auto-diagnosis and alarm function make the operation more user friendly.

##### 8. Remote monitoring:

Equipped LY506A control board for microprocessor controller system. Together with DM23 touch screen interface and RS485 communication transmission technology, it can reach a long data transmission distance up to 1200 m without signal attenuation. If a relay is added, the communication distance can go beyond 3000 m! Furthermore, it can connect up to 16 modules under one RS485.

### World famous brand compressor

We equip world famous brand compressors on our chillers. They are high efficiency and reliable. These compressors have excellent IPLV by their built-in continuous or four(three)-stage capacity control.



- 1) High efficiency screw rotor with patent in many countries.
- 2) Ultra long life bearing.
- 3) The motor uses high quality silicon steel with specially designed slots for internal and external cooling as well as minimized inlet/outlet pressure design.
- 4) Four capacity control solenoid valves can set four-stage (25%-50%-75%-100%) capacity modulation and 25% to 100% continuous capacity modulation.
- 5) Four directional air exhaust check valve and stop valve.

### Screw compressor series

#### High Efficiency Shell-and-tube Exchanger

- A. Each chiller equips Chinese national certificated BR1 grade high efficiency horizontal shell and tube heat exchanger. All our heat exchangers used meet the standards of GB150 (steel pressure vessel regulation); GB151 (shell and tube heat exchanger regulation); JB/T4750-2003 (refrigeration purpose pressure vessel) and the other national relevant industry regulations.
- B. The world's most advanced high efficiency heat transfer tubes are adopted in our heat exchangers. They have multi-head spiral ribs and threaded shapes on inner wall surface so that can effectively improve the heat transfer efficiency and heat exchange ability. They are processed and finished by numerical control operation and welded by automatic machines. All the heat exchangers pass the national pressure vessel tests and certify by national relevant organization.
- C. Inside of the evaporator is specially optimized designed by fluid dynamic. It also installs high efficiency fluid equalizer so that it can resolve the system medium distribution un-equality problem so that the heat exchange efficiency is 50% higher than traditional heat exchangers.
- D. Improve the seal structure of the water board to solve the serial problems of leakage so that highly improve the heat exchange efficiency of evaporator and reduce the water resistance at the same time. By this to ensure the high quality level under normal operation.
- E. Unique design technique for heat exchanger and refrigeration flow optimize the whole system and ensure the balance of refrigeration process and water-side capacity, thus it can bring the heat exchanger into full performance to save energy.
- F. Simple system structure, steady heat exchanging, easy to maintain and repair, elegant appearance, compact size, excellent heat exchanging capacity and reliable.



High efficiency shell and tube heat exchanger

#### Opposited M shape condenser

- A. Specially anti-corrosion treatment on the surface of heat exchanger aluminum fins to improve the corrosion resistibility of the fins and prolong the heat exchanger operation life time.
- B. Air-cooled condenser are copper-aluminum fin structure made by imported aluminum fins and copper tubes. High efficiency internal threaded copper tubes and extra thin aluminum fins are formed by swelling machine to ensure their tight contact for high heat exchange efficiency and ability.
- C. Advanced cleaning technique is introduced during the processing to make the surface of condenser extremely clean. Thus ensure the high heat exchanging efficiency.
- D. Unique design technique for heat exchanger reasonably match the air volume and air speed to ensure the balance of refrigerating process and air speed, thus it can bring the compressor and heat exchanger into full performance to achieve high efficiency and energy saving.
- E. Unique opposite M shape arrange for condenser. This arrangement is compact sized, space saving, evenly air flow passing. It overcomes the traditional type's air short problem, thus bring the heat exchanger into full performance.



## The product features

### Screw compressor series

#### Microprocessor controller

LY506 microprocessor controller is employed in our control system, together with DM23 touch panel interface. It can display the running status, real time performance curve, malfunction information, historical record... etc. Also can control on/off through it as well.

The features are:

- 1) Adopt advanced high processing speed embedded microprocessor, much better performance than single chip models which usually used in this field.
- 2) SMT- surface mounted technique for the system main board so that it can be compact, low radiation and highly anti-interference.
- 3) A preserved serial port in the main board for download programs from PC , thus it is easy for program upgrade and hardware extending.
- 4) RS485 communication transmission technology is employed for long data transmission distance up to 1200 m without signal attenuation. The transmission distance can go beyond 3000 m by adding an extra relay.
- 5) Up to 16 modules can be connected to main RS485 controller.
- 6) Data transmission between main board and other boards can be done by one simple telephone line for easy instal and detach the controllers.
- 7) The chillers have auto-diagnose system so that they can eliminate malfunctions by themselves, also the software adopts trap and redundancy technique combined with WATCHDOG of hardware to improve anti-interference ability.
- 8) Large memory capacity, 512K for program memory capacity, 128K for power off data storage. Steady, reliable memory CMOS chip is used for parameter storage to prevent data lose.
- 9) System preserves PC monitoring and short message control functions.
- 10) Equips 320X240 large high resolution LCD touch panel. It can show 16 rows\* 40 columns = 640 Chinese characters or 1280 signals on screen.
- 11) The screen display has perfect displaying effect, both character and pictures can be displayed clearly with strong three-dimensional effect, especially when it displays gray effect pictures, the three-dimensional effect will be more satisfying. Very easy to operate.
- 12) It is operated by touch panel. Sensitive and comfortable touch screen. The lifespan for each point is more than one million times touch so that ensures the chiller being used for a long time.
- 13) The unique screen protection system can let liquid crystal display be used more than ten years, thus solve the LCD lifespan problem.
- 14) Support multi- controller connection .
- 15) Complete parameters are built in the system. They can be reset according to the real requirements by customers. Password protection function is also available.
- 16) Built-in brief operation manual.
- 17) May check any set point temperature anytime as well as open/close input and relay output, May modify setting temperature anytime and show temperature curve for one day or one hour.
- 18) Present malfunction status and historical malfunctions can be inquired, Statistics function can help to analyze and find out the unstable running parts so that can fix them in time. Historical malfunction records and be inquired by error code, error times and error happening time.
- 19) Remote on/off function, one time on/off settlement and weekly on/off settlement are available. May set up to three on/off daily.
- 20) Multiple displaying styles. May set anyone you like.
- 21) Multi-lingual online transfer function is available.



## Products Specifications

### Air-cooled scroll chiller specifications (R22) Side blow type

Type		Side blow type	Side blow type	Side blow type	Side blow type	Side blow type		
Model		LSQWRF25TB	LSQWRF34TB	LSQWRF45TB	LSQWF25TB	LSQWF36TB	LSQWF47TB	
Cooling capacity	kW	24.8	33.2	44.1	24.8	35.8	46.1	
Heating capacity	kW	25.0	31.8	44.1	—	—	—	
Power supply		3 φ ,380V,50Hz						
Cooling	Power input	kW	9.2	13.0	17.2	9.2	13.70	17.2
	Operation power	A	16.4	23.8	31.9	16.4	25.10	31.9
	Starting current	A	125	175	130	125	175	130
	Energy efficiency ratio	W/W	2.7	2.55	2.56	2.7	2.61	2.70
Heating	Power input	kW	10.0	12.4	16.2	—	—	—
	Operation power	A	17.9	22.5	31.0	—	—	—
	Starting current	A	125	175	130	—	—	—
	Energy efficiency ratio	W/W	2.5	2.56	2.72	—	—	—
Com-pressor	Type	Hermetic scroll compressor						
	Power output	kW	7.5	11.2	7.5x2	7.5	11.2	7.5x2
Fan	Type	Spiral fan	Spiral fan	Spiral fan	Aluminium spiral fan	Aluminium spiral fan	Aluminium spiral fan	
	Power output*quantity	W	430x1	520x1	430x2	430x1	520x1	430x2
	Air flow	m <sup>3</sup> /min	150	160	150x2	150	160	150x2
Water Pump	Type	Axial centrifugal type	Axial centrifugal type	—	Axial centrifugal type	Axial centrifugal type	—	
	Model	CH4-40	CH4-50	—	CH4-40	CH4-50	—	
	Power output	W	645	880	—	645	880	—
	Nominal water flow(Heating)	m <sup>3</sup> /h	4.3	5.7(5.5)	7.6(7.6)	4.3	6.16	7.93
	Head	kPa	196	196	—	196	196	—
	Air side heat exchanger	louver fin and cooper tube type						
	water side heat exchanger	Plate type		shell and tube type	Plate type		shell and tube type	
	Refrigerant Type	R-22						
	Charging Volume	kg	5.6	10.8	7.8x2	5.6	10.8	7.3x2
	Safety Devices	High pressure switch, low pressure switch, anti-freeze switch, water pump overload protection, compressor overheat protection, fan motor overheat protection, phase relay etc.						
Dimension	Height	mm	1750/1920	1990/2160	1635/1840	1750X1920	1990X2160	1635X1840
	width	mm	1150/1250	1480/1580	2010/2170	1150X1250	1480X1580	2010X2170
	Depth	mm	478/588	478/588	720/850	478X588	478X588	720X850
Weight	Before packing	kg	270	400	720	270	400	720
	After packing	kg	290	435	760	290	435	760
Compressor crankcase heater	w	70	70	70x2	—	—	—	
Piping Size	inch/mm	1"/DN25	1 1/2"/DN40	2"/DN50	1"/DN25	1 1/2"/DN40	2"/DN50	

1. Cooling capacity is measured under conditions of outdoor 35°C DB; chilled water inlet 12°C; chilled water outlet 7°C
2. Heating capacity is measured under conditions of outdoor 7°C DB, 6° WB; hot water inlet 40°C; hot water outlet 45°C
3. Heating function can be operated normally under ambient temperature as low as -10°C
4. The specifications are subject to change without prior notification



## Outline Dimensions

### LSQWF25TB

1. Chilled water inlet 1"
2. Chilled water outlet 1"
3. Power wiring hole
4. Drain hole 1"

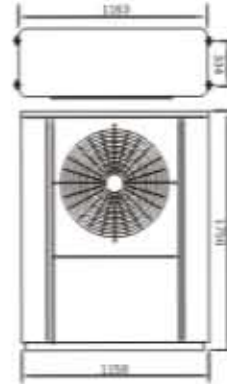
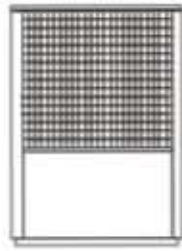

Cooling Only Type

### LSQWF36TB

1. Chilled water inlet 1-1/2"
2. Chilled water outlet 1-1/2"
3. Power wiring hole
4. Drain hole 1"

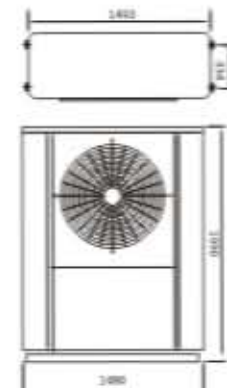
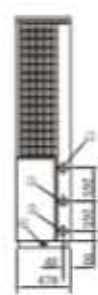
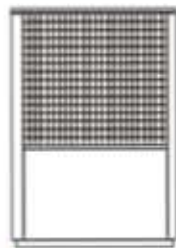

Cooling Only Type

### LSQWF47TB

Cooling Only Type

1. Chilled water inlet PT 2"
2. Chilled water outlet PT 2"
3. Power wiring hole  $\phi$  30
4. Drain hole PT 1"

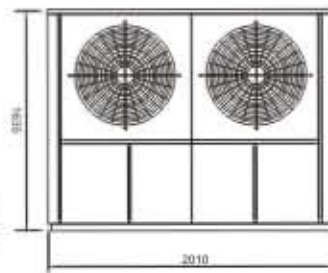
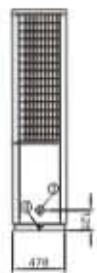
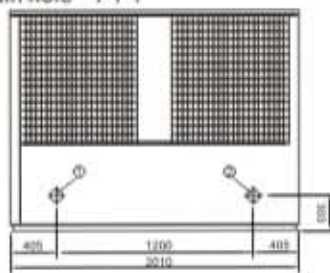

## Outline Dimensions

### LSQWRF25TB

1. Chilled water inlet 1"
2. Chilled water outlet 1"
3. Power wiring hole
4. Drain hole 1"

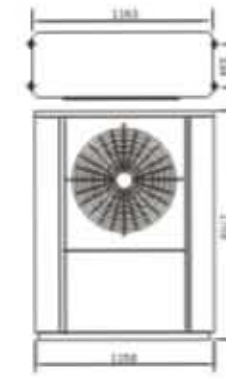

Heat Pump

### LSQWRF34TB

1. Chilled water inlet 1-1/2"
2. Chilled water outlet 1-1/2"
3. Power wiring hole
4. Drain hole 1"

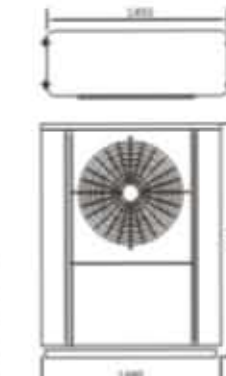
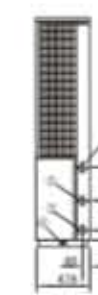
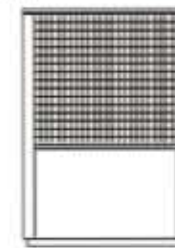

Heat Pump

### LSQWRF45TB

Heat Pump

1. Chilled water inlet PT 2"
2. Chilled water outlet PT 2"
3. Power wiring hole
4. Drain hole PT 1"

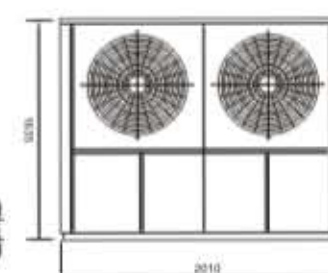
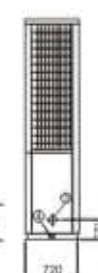
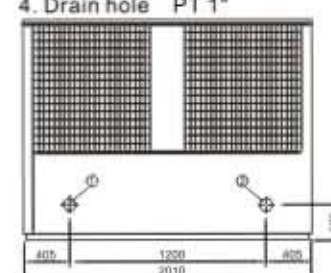



## Products Specifications

### Air-cooled chiller specifications (R22) Top Discharge Type

Item	Model	LSQWRF 60TA	LSQWRF 90TA	LSQWRF 120TA	LSBLGRF 160TSA	LSBLGRF 200TSA	LSBLGRF 240TSA
Cooling capacity(kW)		60	90	120	160	200	240
Heating capacity(kW)		65	98	130	176	220	264
Power supply		3φ-380V-50Hz					
Cooling	Power input(kW)	18.64	27.95	37.27	49.2	61.3	74.5
	Operation current(A)	33.0	48.0	61.0	99.30	114.5	165.4
	Starting current (A)	140.0	175.0	230.0	275.0	445.0	510.0
Heating	Power input(KW)	17.8	26.85	35.6	48.4	60.9	73.3
	Operation current (A)	32.0	46.0	59.5	97.80	103.0	157.4
	Starting current (A)	140.0	175.0	230.0	275.0	445.0	510.0
Com-pressor	Type	Hermetic scroll type			Semi-hermetic screw type		
	Startup type	Direct Startup			Y-Δ startup		
	Oil heater (W)	70x2	70x2	90x2	300	300	300
Fan Blower	Type*quantity	Axial typex2	Axial typex2	Axial typex4	Axial typex4	Axial typex4	Axial typex6
	Power Consumption(W)	1680	1680	3720	5000	5000	7500
	Air Flow (m <sup>3</sup> /h)	26000	39000	52000	60,000	60,000	90,000
Evaporator	Condenser	Hydrophilic aluminum fin type			Fin louver plate type		
	Type	Shell and tube type			Shell and tube type		
	Water flow(m <sup>3</sup> /h)	10.3	15.5	20.6	27.5	34.4	41.3
Refrigerant	Head loss(kPa)	27.0	39.2	49.0	51.0	54.9	57.0
	Water pipe connector	DN125	DN125	DN 125	DN80	DN80	DN 100
	Type	R22					
Dimension	Charge volume(kg)	15	18.4	36.0	56.0	68.0	85.0
	Height (mm)	2190	2190	2190	2380	2380	2380
	Width (mm)	1870	1870	1870	2436	2436	3086
Net Weight (KG)	Depth (mm)	920	1120	1800	2096	2096	2096
	Net Weight (KG)	720	820	1300	2050	2350	2550
	Operation Weight(KG)	760	870	1350	2095	2410	2610
Operation noise(dBA)		71	72	74	80	82	82

Note: Cooling mode working conditions : water inlet temperature 12°C, water outlet temperature 7°C, ambient 35°C DB.  
 Heating mode working conditions : water inlet temperature 40°C, water outlet temperature 45°C, ambient 6°C WB.  
 If the real working condition is different ,the capacity will be different.

## Outline Dimensions

### LSQWRF60TA Outline Dimensions

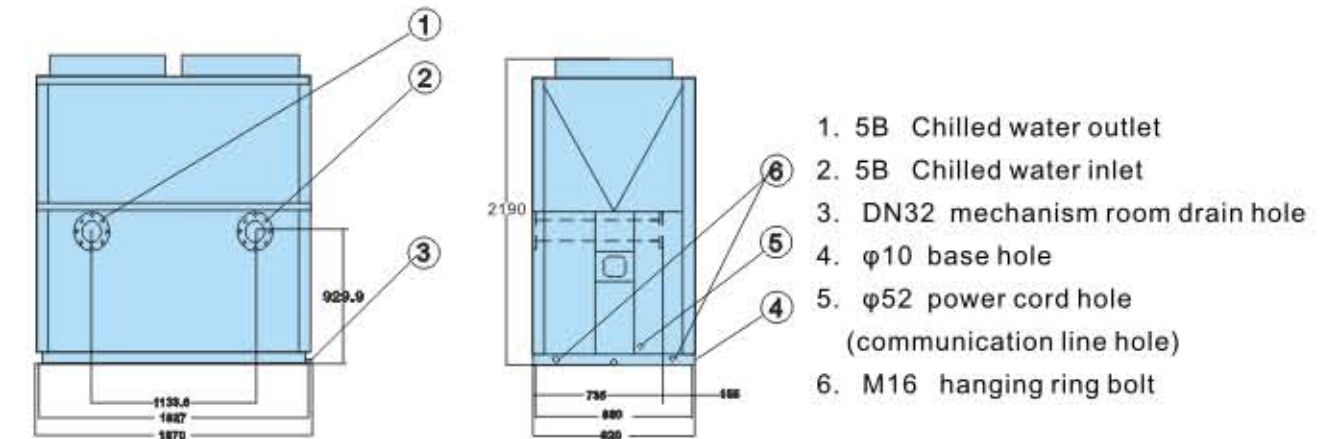

### LSQWRF90TA Outline Dimensions

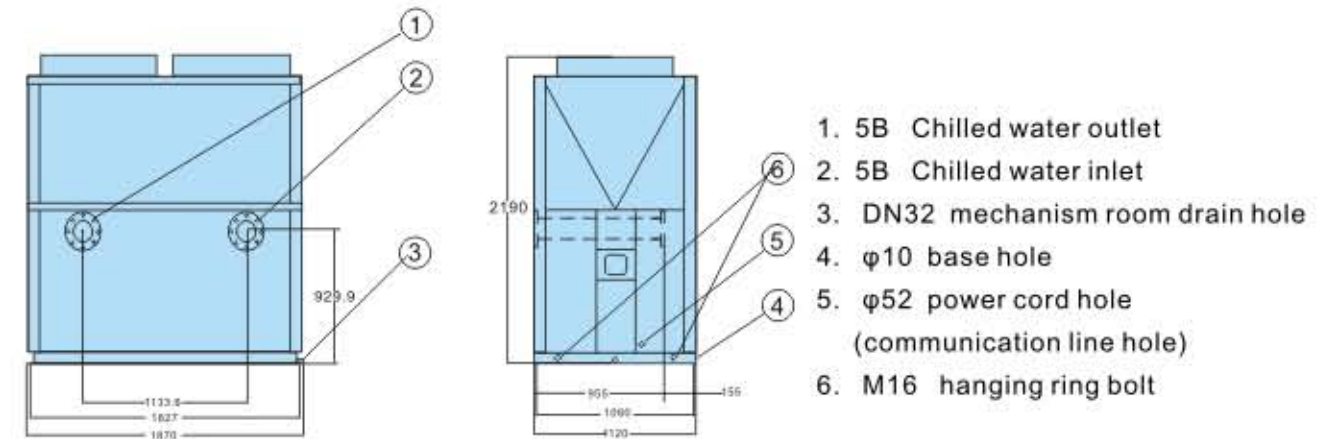

### LSQWRF120TA Outline Dimensions

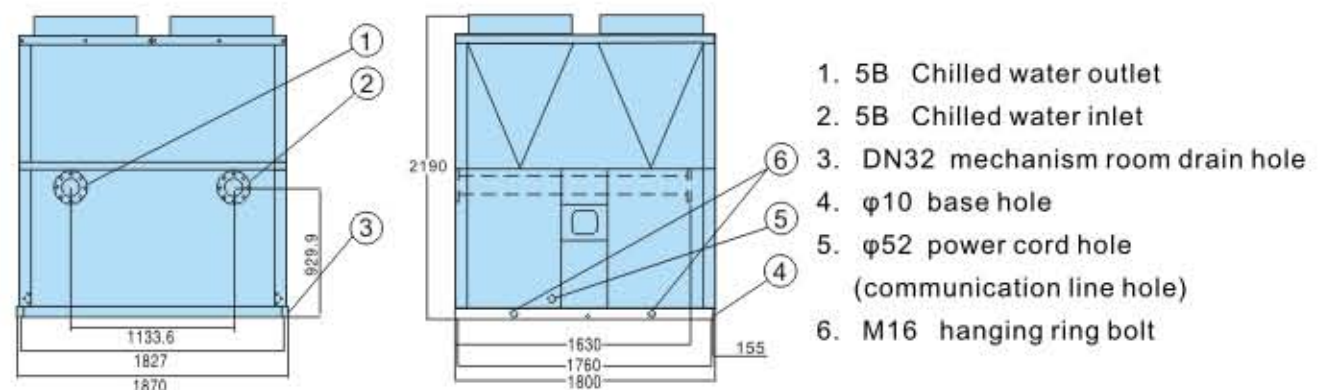



## Outline Dimensions

LSBLGRF160TSA Outline Dimensions

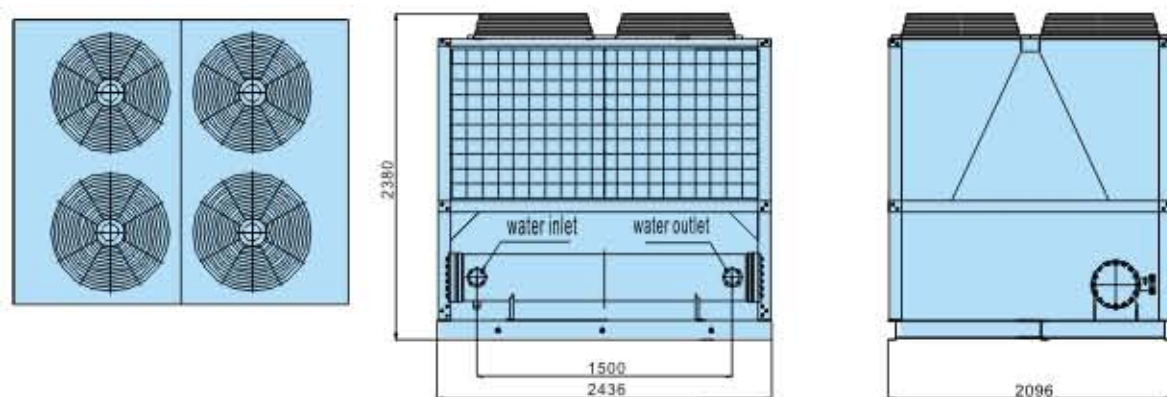

LSBLGRF200TSA Outline Dimensions

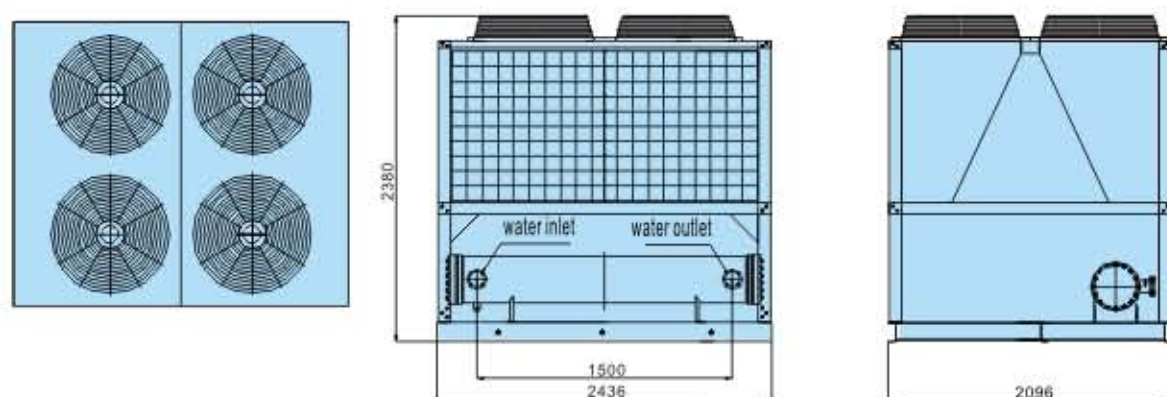

LSBLGRF240TSA Outline Dimensions

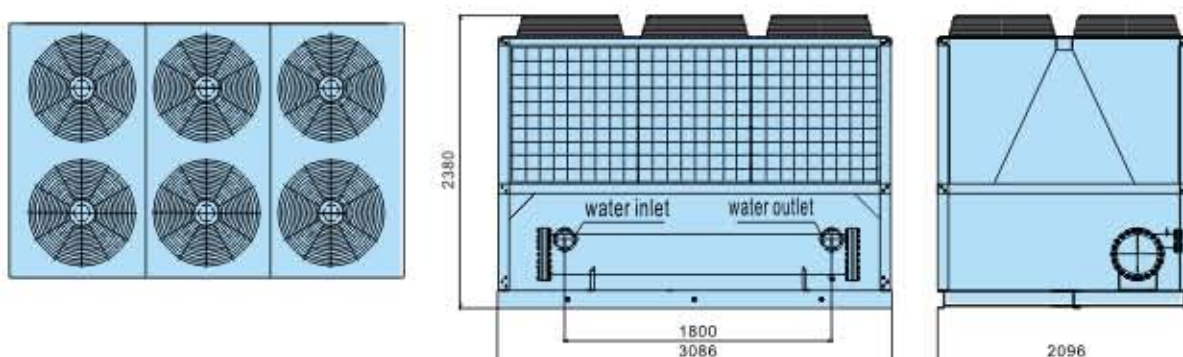

## Air-cooled modular chiller



### Flexible combination

Modular design, combined by module units, 1 to 15 module units can be selected and combined based on different capacity requirements. For enlarging capacity, just add modules in or select suitable modules to form a set and connect to the existing system, then it can work properly.



### Convenient installation

Connect water inlet and outlet on one single module then the whole system's piping job is done. It is unnecessary to connect pipe for every individual unit.

Use rubber hoses to connect modules, easy to install.



### Compact structure and simple maintenance

The structure of module unit is compact and easy for maintenance. According to on-site requirement, the modules can be installed zero distance or at intervals.



### Easy control, optimized and power saving

When the modules are running, the micro computer controller automatically adjusts module capacity or on/off corresponding modules according to system load requirement.

Power saving for any time. Each module unit adopts dual compressors so that the system capacity adjusting range becomes even wider after combination.

### Famous brand fittings make a high reliability

Adopt world famous scroll compressors with stable performance. Adopt European famous brand fan motor with high efficiency, durability and reliability, the service life reaches 40 thousand hours. F grade insulation and excellent waterproof feature. Rigid fan, high air pressure and air volume.



### Centralized control and remote control

RS485 communications device (option) can perform remote control over the module sets as well as the microcomputer network control.



## Products Specifications

### Air-cooled modular scroll type chiller (R22)

Model		LSQWRF 150T2A	LSQWRF 180T2A	LSQWRF 210T2A	LSQWRF 240T2A	LSQWRF 270T3A	LSQWRF 300T3A	LSQWRF 330T4A	LSQWRF 360T3A	
Cooling capacity	kW	150	180	210	240	270	300	330	360	
Heating capacity	kW	163	196	228	260	294	326	359	390	
Power supply	Ø.V.Hz	3Ø-380V-50Hz								
Cooling	Power input	kW	46.6	55.9	65.2	74.5	84	93	102.5	111.8
	Operation current	A	81.0	96.0	109.0	122.0	144	157	177.0	183.0
	Starting current	A	232.0	247.0	308.5	321.5	295.0	356.5	300.5	382.5
Heating	Power input	kW	44.7	53.7	62.5	71.2	81	89	98.4	106.9
	Operation current	A	78.0	92.0	105.5	119.0	138	152	170.0	178.5
	Starting current	A	230.0	244.0	305.8	319.3	290.0	351.8	294.0	378.8
Com-pressor	Type	Hermetic...scroll								
	Power input	kW	8.5x2+13.62x2	13.62x4	13.62x2+18.78x2	18.78x4	13.62x6	13.62x4+18.78x2	13.62x6+8.5x2	18.78x6
	Crankcase heater	W	70x4	70x4	70x2+90x2	90x4	70x6	70x4+90x2	70x8	90x6
blower	Type x quantity	Axialx4 Axialx4 Axialx6 Axialx8 Axialx6 Axialx8 Axialx8 Axialx12								
	Power	W	2720	3360	3360	7440	5040	5800	6720	11160
	Air volume	m <sup>3</sup> /h	65000	78000	91000	104000	117000	130000	143000	156000
Water side heat exchanger	Shell and tube type									
Air side heat exchanger	Hydrophilic aluminum fin type									
Water flow	m <sup>3</sup> /h	25.8	31.0	36.1	41.3	46.4	51.60	56.8	61.9	
Resistance	KPa	49.2	49.2	59.0	59.0	59.2	69.0	69.2	69.0	
Noise level (dBA)		74	75	76	77	77	78	78	78	
Refrigerant	type	R22								
	Charge volume	Kg	33.4	36.8	54.4	72.0	55.2	73	70.2	108.0
Dimension	Height	mm	2190	2190	2190	2190	2190	2190	2190	2190
	Width	mm	1870	1870	1870	1870	1870	1870	1870	1870
	Depth	mm	2040	2240	2920	3600	3360	4040	4280	5400
Weight	Net	Kg	1540	1640	2120	2600	2460	2940	3180	3900
	Gross	Kg	1630	1740	2220	2700	2610	3090	3370	4050
Piping Size	inch/mm	5"/DN125								

- Cooling capacity is measured under conditions of outdoor 35 °C DB, chilled water inlet 12 °C , chilled water outlet 7 °C
- Heating capacity is measured under conditions of outdoor 7 °C DB, 6 °C WB, hot water inlet 40 °C , hot water outlet 45 °C
- The working ambient temperature can be as low as -10 °C .
- The specifications above are subject to change without prior notice.
- LMK15AC (central control displayer) is an option according to customer's requirement.

## Products Specifications

### Air-cooled modular scroll type chiller (R22)

Model		LSQWRF 420T5A	LSQWRF 450T5A	LSQWRF 480T4A	LSQWRF 540T6A	LSQWRF 570T5A	LSQWRF 600T5A	LSQWRF 660T6A	LSQWRF 720T6A	LSQWRF 780T7A	LSQWRF 840T7A	LSQWRF 930T8A	LSQWRF 990T9A	
Cooling capacity	kW	420	450	480	540	570	600	660	720	780	840	930	990	
Heating capacity	kW	457	490	520	588	618	650	715	780	845	910	1008	1073	
Power supply	Ø.V.Hz	3Ø-380V-50Hz												
Cooling	Power input	kW	130.4	139.8	149.1	167.7	177.0	186.4	205	223.6	242.3	260.9	288.8	307
	Operation current	A	225.0	240.0	244.0	288.0	292.0	305.0	338	366.0	399.0	427.0	475.0	508
	Starting current	A	348.5	391.0	443.5	439.0	443.0	504.5	537.5	565.5	522.5	626.5	626.0	659.0
Heating	Power input	kW	125.2	134.3	142.5	161.1	169.3	178.1	196	213.7	231.5	249.3	276.2	294
	Operation current	A	216.0	230.0	238.0	276.0	284.0	297.5	330	357.0	389.0	416.5	462.5	495
	Starting current	A	340.0	382.0	438.3	428.0	436.0	497.8	529.8	557.3	513.0	616.8	614.5	646.5
Com-pressor	Type	Hermetic...scroll												
	Power input	W	13.62x6+8.5x2	13.62x10	18.78x8	13.62x12	18.78x10	18.78x10	18.78x10+4.5x2	18.78x12	18.78x12+4.5x2	18.78x14	18.78x14+3.62x2	18.78x14+3.62x2
	Crankcase heater	W	70x10	70x10	90x8	70x12	90x8+70x2	90x10	90x10+70x2	90x12	90x12+70x2	90x14	90x14+70x2	90x14+70x4
Fan	Type x quantity	Axialx10 Axialx10 Axialx16 Axialx12 Axialx18 Axialx20 Axialx22 Axialx24 Axialx26 Axialx28 Axialx30 Axialx32												
	Power	W	8400	8400	14880	10080	16560	18600	20280	22320	24000	26040	27720	29400
	Air volume	m <sup>3</sup> /h	182000	195000	208000	234000	247000	260000	286000	312000	338000	364000	403000	429000
Water side heat exchanger	Shell and tube type													
Air side heat exchanger	Hydrophilic aluminum fin type													
Water flow	m <sup>3</sup> /h	72	77.4	82.6	92.9	98.0	103.2	114	123.8	134.2	144.5	160.0	170	
Water resistance	KPa	79.2	79.2	79.0	89.2	89.0	89.0	99.0	99.0	109.0	109.0	119.0	119.2	
Noise level (dBA)		79	79	80	80	81	81	82	82	83	83	84	84	
Refrigerant	type	R22												
	Charge volume	Kg	88.6	92	144	110.4	162.4	180	195	216	231	252	270	285
Dimension	Height	mm	2190	2190	2190	2190	2190	2190	2190	2190	2190	2190	2190	
	Width	mm	1870	1870	1870	1870	1870	1870	1870	1870	1870	1870	1870	
	Depth	mm	5400	5600	7200	6720	8320	9000	9920	10800	11720	12600	13720	14640
Weight	Net	Kg	4000	4100	5200	4920	6020	6500	7220	7800	8520	9100	9920	10640
	Gross	Kg	4240	4350	5400	5220	6270	6750	7510	8100	8860	9450	10320	11080
Piping Size	inch/mm	5"/DN125												

- Cooling capacity is measured under conditions of outdoor 35 °C DB, chilled water inlet 12 °C , chilled water outlet 7 °C
- Heating capacity is measured under conditions of outdoor 7 °C DB, 6 °C WB, hot water inlet 40 °C , hot water outlet 45 °C
- The working ambient temperature can be as low as -10 °C .
- The specifications above are subject to change without prior notice.
- LMK15AC (central control displayer) is an option according to customer's requirement.



## Products Specifications

### Air-cooled screw chiller specifications (R22)

Model		LSBLGRF 320T2A	LSBLGRF 360T2A	LSBLGRF 400T2A	LSBLGRF 440T2A	LSBLGRF 480T2A
Item						
	Cooling capacity(kW)	320	360	400	440	480
	Heating capacity(kW)	352	396	440	484	528
	Power supply(φ-V-Hz)	3φ-380V-50Hz				
Cooling	Power input(kW)	98.5	110.6	122.7	135.9	149.1
	Operation current(A)	198.6	213.8	264.7	279.9	330.8
	Starting current (A)	550.0	720.0	785.0	955.0	1020.0
Heating	Power input(kW)	96.7	109.3	121.7	134.3	146.7
	Operation current (A)	195.6	200.8	255.2	260.4	314.8
	Starting current (A)	550.0	720.0	785.0	955.0	1020.0
Com-pressor	Type	Semi-hermetic dual screw type				
	Startup type	Y-Δ startup				
	Oil heater (W)	300x2	300x2	300x2	300x2	300x2
Fan Blower	Type x quantity	Axial x8	Axialx8	Axialx10	Axialx10	Axialx12
	Power Consumption(W)	10,000	10,000	12,500	12,500	15,000
	Air Flow (m <sup>3</sup> /h)	120,000	120,000	150,000	150,000	180,000
Condenser		Louver fin plate type				
Evaporator	Type	Shell and tube type				
	Water flow(m <sup>3</sup> /h)	55.0	61.9	68.8	75.7	82.6
	Head loss	61.2	64.9	67.0	67.0	67.0
	Water pipe connector	DN 80x2	DN 80x2	DN80+DN100	DN80+DN100	DN100x2
Refrigerant	Type	R22				
	Charge volume (kg)	112.0	124.0	141.0	153.0	170.0
Dimension	Height (mm)	2380	2380	2380	2380	2380
	Width (mm)	4872	4872	5522	5522	6172
	Depth (mm)	2096	2096	2096	2096	2096
	Net Weight (kg)	4100	4400	4600	4900	5100
	Operation Weight(kg)	4160	4460	4660	4960	5160
	Operation noise level(dBA)	80	82	82	82	82

1. Cooling capacity is measured under conditions of outdoor 35 °C DB, chilled water inlet 12°C , chilled water outlet 7°C
2. Heating capacity is measured under conditions of outdoor 7 °C DB, 6 °C WB, hot water inlet 40°C , hot water outlet 45°C
3. The working ambient temperature can be as low as -10°C .
4. The specifications above are subject to change without prior notice.
5. LMK15AC (central control displayer) is an option according to customer's request.

## Products Specifications

### Air-cooled screw chiller specifications (R22)

Model		LSBLGRF 520T3A	LSBLGRF 560T3A	LSBLGRF 600T3A	LSBLGRF 640T3A	LSBLGRF 680T3A	LSBLGRF 720T3A	LSBLGRF 760T4A	LSBLGRF 800T4A
Item									
	Cooling capacity(kW)	520	560	600	640	680	720	760	800
	Heating capacity(kW)	572	616	660	704	748	792	836	880
	Power supply(φ-V-Hz)	3φ-380V-50Hz							
Cooling	Power input(kW)	159.8	171.9	184.0	197.2	210.4	223.6	233.3	245.4
	Operation current(A)	313.1	328.3	343.5	394.4	445.3	496.2	442.8	458.0
	Starting current (A)	995	1165	1335	1400	1465	1530	1610	1780
Heating	Power input(KW)	157.6	170.2	182.8	195.2	207.6	220.0	231.2	243.8
	Operation current (A)	298.6	303.8	309.0	363.4	417.8	472.2	406.8	412.0
	Starting current (A)	995	1165	1335	1400	1465	1530	1610	1780
Com-pressor	Type	Semi-hermetic dual screw type							
	Startup type	Y-Δ startup							
	Oil heater (W)	300x3	300x3	300x3	300x3	300x3	300x3	300x4	300x4
Fan Blower	Type x quantity	Axialx12	Axialx12	Axialx12	Axialx14	Axialx16	Axialx18	Axialx16	Axialx16
	Power Consumption(W)	15,000	15,000	15,000	17,500	20,000	22,500	20,000	20,000
	Air Flow (m <sup>3</sup> /h)	180,000	180,000	180,000	210,000	240,000	270,000	240,000	240,000
Condenser		Louver fin plate type							
Evaporator	Type	Shell and tube type							
	Water flow(m <sup>3</sup> /h)	89.4	96.3	103	110.1	117.0	123.9	130.7	137.6
	Head loss	64.9	64.9	67.0	67.0	67.0	67.0	68.9	69.0
	Water pipe connector	DN 80x3	DN 80x3	DN 80x2+DN100	DN80+DN100x2	DN80+DN100x2	DN 100x3	DN 80x4	DN 80x4
Refrigerant	Type	R22							
	Charge volume(kg)	180	192	204	212	238	255	260	272
Dimension	Height (mm)	2380	2380	2380	2380	2380	2380	2380	2380
	Width (mm)	7308	7308	7308	7958	8608	9258	9744	9744
	Depth (mm)	2096	2096	2096	2096	2096	2096	2096	2096
	Net Weight (kg)	6450	6750	7050	7250	7450	7650	9100	9400
	Operation Weight(kg)	6510	6810	7110	7310	7510	7710	9160	9460
	Operation noise(dBA)	82	82	82	82	82	82	82	82

1. Cooling capacity is measured under conditions of outdoor 35 °C DB, chilled water inlet 12°C , chilled water outlet 7°C
2. Heating capacity is measured under conditions of outdoor 7 °C DB, 6 °C WB, hot water inlet 40°C , hot water outlet 45°C
3. The working ambient temperature can be as low as -10°C .
4. The specifications above are subject to change without prior notice.
5. LMK15AC (central control displayer) is an option according to the customer's request.



## Products Specifications

### Air-cooled screw chiller specifications (R22)

Item	Model	LSBLGRF	LSBLGRF	LSBLGRF	LSBLGRF	LSBLGRF	LSBLGRF	LSBLGRF	LSBLGRF	LSBLGRF	
		840T4A	880T4A	920T4A	960T4A	1000T5A	1040T5A	1080T5A	1120T5A	1160T5A	1200T5A
Cooling capacity(kW)		840	880	920	960	1000	1040	1080	1120	1160	1200
Heating capacity(kW)		924	968	1012	1056	1100	1144	1188	1232	1276	1320
Cooling/Heating COP(W/W)		3.24/3.61	3.24/3.60	3.23/3.60	3.24/3.60	3.26/3.61	3.25/3.61	3.24/3.61	3.24/3.60	3.23/3.60	3.22/3.60
Power supply(φ-V-Hz)		3φ-380V-50Hz									
Cooling	Power input(kW)	258.6	271.8	285.0	298.1	306.7	319.9	333.1	346.3	359.5	372.7
	Operation current(A)	508.9	559.8	610.7	661.6	572.5	623.4	674.3	725.2	776.1	827.0
	Starting current (A)	1845.0	1910.0	1975.0	2040.0	2225.0	2290.0	2355.0	2420.0	2485.0	2550.0
Heating	Power input(KW)	256.2	268.6	280.9	293.3	304.7	317.1	329.5	341.9	354.3	366.7
	Operation current (A)	466.4	520.8	575.2	629.6	515.0	569.4	623.8	678.2	732.6	787.0
	Starting current (A)	1845.0	1910.0	1975.0	2040.0	2225.0	2290.0	2355.0	2420.0	2485.0	2550.0
Compressor	Type	Semi-hermetic dual screw type									
	Startup type	Y-Δ startup									
	Oil heater (W)	300x4	300x4	300x4	300x4	300x5	300x5	300x5	300x5	300x5	300x5
Fan Blower	Type x quantity	Axialx18	Axialx20	Axialx22	Axialx24	Axialx20	Axialx22	Axialx24	Axialx26	Axialx26	Axialx30
	Power Consumption(W)	22,500	25,000	27,500	30,000	25,000	27,500	30,000	32,500	35,000	37,500
	Air Flow (m <sup>3</sup> /h)	270,000	300,000	330,000	360,000	300,000	330,000	360,000	390,000	420,000	450,000
Evaporator	Condenser	Louver fin plate type									
	Type	Shell and tube type									
	Water flow(m <sup>3</sup> /h)	144.5	151.4	158.3	165.2	172.0	178.9	185.8	192.7	199.6	206.5
	Head loss	69.0	69.0	69.9	69.9	68.9	68.9	69.0	69.0	69.0	69.9
	Water pipe connector	DN80x3+DN100	DN80x2+DN100x2	DN100x3+DN80	DN100x4	DN80x5	DN80x4+DN100x1	DN80x2+DN100x3	DN80x1+DN100x4	DN80x1+DN100x4	DN100x5
Refrigerant	Type	R22									
	Charge volume(kg)	289.0	306.0	323.0	340.0	340.0	357.0	348.0	391.0	408.0	425.0
Dimension	Height (mm)	2380	2380	2380	2380	2380	2300	2300	2300	2300	2300
	Width (mm)	10394	11044	11694	12344	12180	12830	13480	14130	14780	15430
	Depth (mm)	2096	2096	2096	2096	2096	2096	2096	2096	2096	2096
	Net Weight (kg)	9600	9800	10000	10200	11750.0	11950	12150	12350	12550	12750
	Operation Weight(kg)	9645	9860	10060	10260	11810	12010	12210	12410	12610	12810
	Operation noise level(dBA)	82	82	82	82	82	82	82	82	82	82

Note: Cooling mode working conditions : water inlet temperature 12°C, water outlet temperature 7°C, ambient 35°C DB.  
 If the real working condition is different, the cooling capacity will be different.  
 Heating mode working conditions : water inlet temperature 40°C, water outlet temperature 45°C, ambient 6°C WB.  
 If the real working condition is different, the heating capacity will be different.

## Products Specifications

### Air-cooled screw chiller specifications (R22)

Item	Model	LSBLGRF	LSBLGRF	LSBLGRF	LSBLGRF	LSBLGRF	LSBLGRF	LSBLGRF	LSBLGRF
		1240T6A	1280T6A	1320T6A	1360T6A	1400T6A	1440T6A	1640T7A	1680T7A
Cooling capacity(kW)		1240	1280	1320	1360	1400	1440	1640	1680
Heating capacity(kW)		1364	1408	1452	1496	1540	1584	1804	1848
Cooling/Heating COP(W/W)		3.25/3.61	3.25/3.61	3.24/3.61	3.23/3.60	3.23/3.60	3.22/3.60	3.23/3.60	3.22/3.60
Power supply(φ-V-Hz)		3φ-380V-50Hz							
Cooling	Power input(kW)	381.3	394.5	407.7	420.8	434.0	447.2	508.6	521.7
	Operation current(A)	737.9	788.8	839.7	890.6	941.5	992.4	1106.9	1157.8
	Starting current (A)	2735	2800	2865	2930	2995	3060	3505	3570
Heating	Power input(KW)	378.0	390.4	402.8	415.2	427.6	440.0	500.9	513.3
	Operation current (A)	672.4	726.8	781.2	835.6	890.0	944.4	1047.4	1101.8
	Starting current (A)	2735	2800	2865	2930	2995	3060	3505	3570
Compressor	Type	Semi-hermetic dual screw type							
	Startup type	Y-Δ startup							
	Oil heater (W)	300x6	300x6	300x6	300x6	300x6	300x6	300x7	300x7
Fan Blower	Type x quantity	Axialx26	Axialx28	Axialx30	Axialx32	Axialx34	Axialx36	Axialx40	Axialx42
	Power Consumption(W)	32,500	35,000	37,500	40,000	42,500	45,000	50,000	52,500
	Air Flow (m <sup>3</sup> /h)	390,000	420,000	450,000	480,000	510,000	540,000	600,000	630,000
Evaporator	Condenser	Louver fin plate type							
	Type	Shell and tube type							
	Water flow(m <sup>3</sup> /h)	213.3	220.2	227.1	234.0	240.9	247.8	282.2	289.1
	Head loss	68.9	68.9	69.0	69.9	70.9	70.9	70.9	70.9
	Water pipe connector	DN80x5+DN100x1	DN80x4+DN100x2	DN80x3+DN100x3	DN80x2+DN100x4	DN80+DN100x5	DN100x6	DN80x1+DN100x6	DN100x7
Refrigerant	Type	R22							
	Charge volume(kg)	425	442	459	476	493	510	578	595
Dimension	Height (mm)	2300	2300	2300	2300	2300	2300	2300	2300
	Width (mm)	15266	15916	16566	17216	17866	18516	20952	21602
	Depth (mm)	2096	2096	2096	2096	2096	2096	2096	2096
	Net Weight (kg)	14300	14500	14700	14900	15100	15300	17650	17850
	Operation Weight(kg)	14360	14560	14760	14960	15160	15360	17710	17910
	Operation noise level(dBA)	82	82	82	82	82	82	82	82

Note: Cooling mode working conditions : water inlet temperature 12°C, water outlet temperature 7°C, ambient 35°C DB.  
 If the real working condition is different, the cooling capacity will be different.  
 Heating mode working conditions : water inlet temperature 40°C, water outlet temperature 45°C, ambient 6°C WB.  
 If the real working condition is different, the heating capacity will be different.



# Installation

## Scroll Compressor Series.

Unit: mm

Model	Unit Dimension(A)	Combined Dimension
LSQWRF60TA	920	n x A
LSQWRF90TA	1120	
LSQWRF120TA	1800	

Note:

It is possible for the modules to be connected with zero distance. Zero-distance connection can be achieved as following:

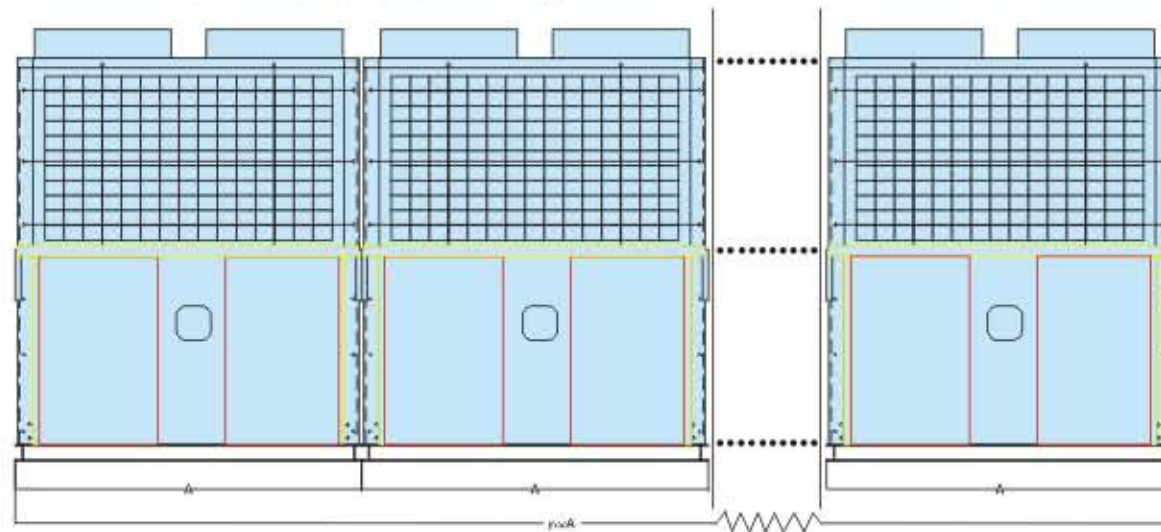

## The Combination Dimensions

Unit: mm

Item	Model	180T2A	240T2A	270T3A	360T3A	450T5A	480T4A	540T6A	600T5A
Width of module anchor bolts interval	D	1827	1827	1827	1827	1827	1827	1827	1827
Width of module	C	1870	1870	1870	1870	1870	1870	1870	1870
Depth of module anchor bolts interval	B	1080	1760	1080	1760	1080	1760	1080	1760
Depth of module	A	1120	1800	1120	1800	1120	1800	1120	1800
Depth after combination	n x A	2240	3600	3360	5400	5600	7200	6720	9000
Modules Quantity	n	2	2	3	3	5	4	6	5

Note:

1. The above dimension are zero-distance combination situation.
2. Soft rubber joints to connect modules can order from us or buy from market (it's market standard product).
3. The anchor bolts are φ10 (size) to be fixed on the ground.
4. Can refer to the above form to calculate the other combination dimensions in the same way.

# Installation

## Preserve service space

LSQWRF60TA/90TA

LSQWRF120TA

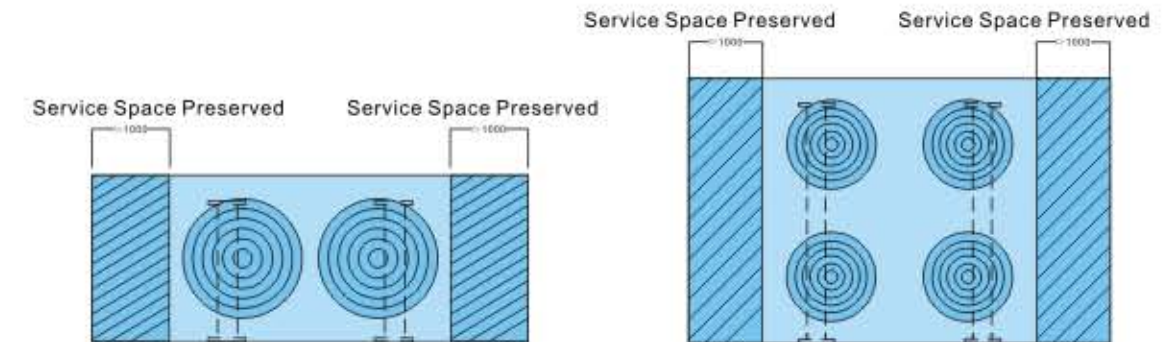

Refer to the following figure to choose the installation base and the install method.

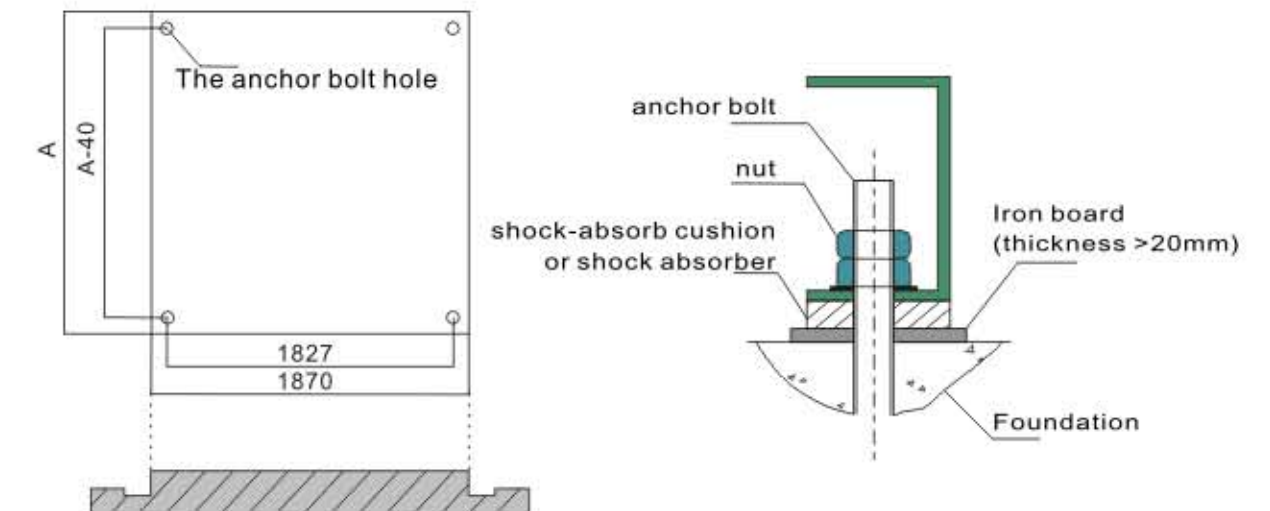

Figure1 the installation base

Figure 2

Remark:

1. Figure 1 indicates one single module's anchor hole position, please pay attention to the modules combination relevance anchor holes' positions while installation.
2. While choosing Figure 2 fixing method, please preserve anchor bolt holes or absorber holes on base by the relevance position from Figure 1.



# Installation

## Installation Precautions

1. Place the unit where it is flat and well ventilated. Leave moderate space around the machine. For details, see the figure above.
2. In units combination, pay attention to the sequence of master and secondary modules, the wire connection and water pipe connection (direct return recommended).
3. Follow the steps in the manual and related notes during installation.

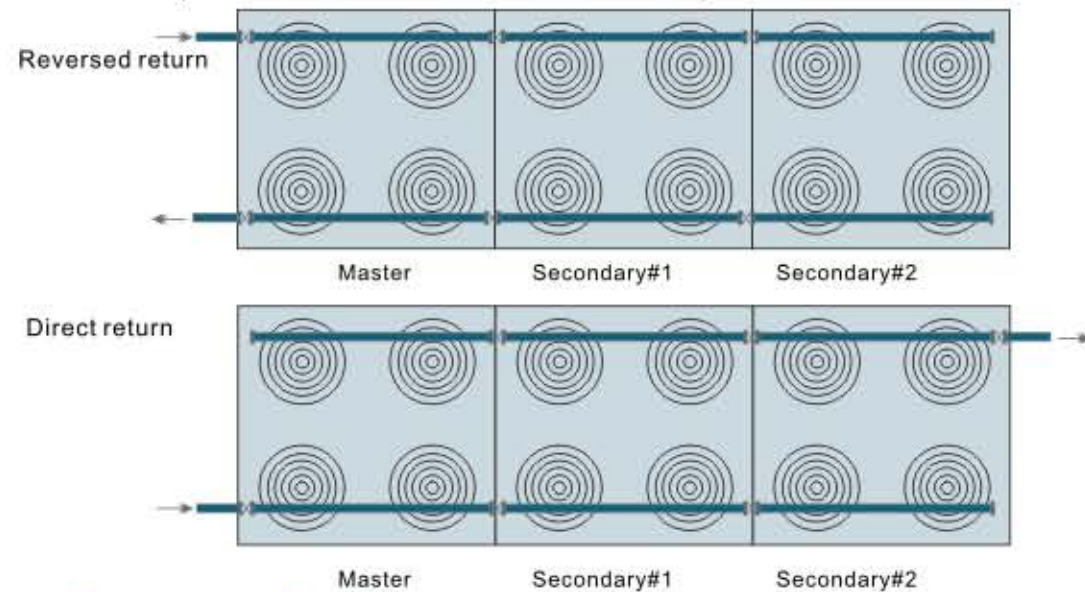

### Screw Compressors Series

#### Installation place and foundation

1. Place the unit on solid and smooth concrete foundation or metal frame. The installation platform strength shall bear the machine weight. If the strength is insufficient, it is very easy to generate vibration and noise.
2. The concrete foundation surface is generally treated with plaster and has waterproof treatment.
3. Draining ditches shall be constructed around the foundation. The slop shall be greater than 0.5%, and incline to the drain opening.
4. Vibration absorber shall be placed between the units and the foundation to avoid the downward transmission of vibration and noise. And the unit shall keep horizontal. Shockproof base may be added if it is necessary.
5. Anchoring measures shall be taken to avoid the unit translocation witch may twist connecting pipes due to earthquake, typhoon or long time operation.

### Module Combination Indicating Figure(LSBLGRF160/200/240TSA)

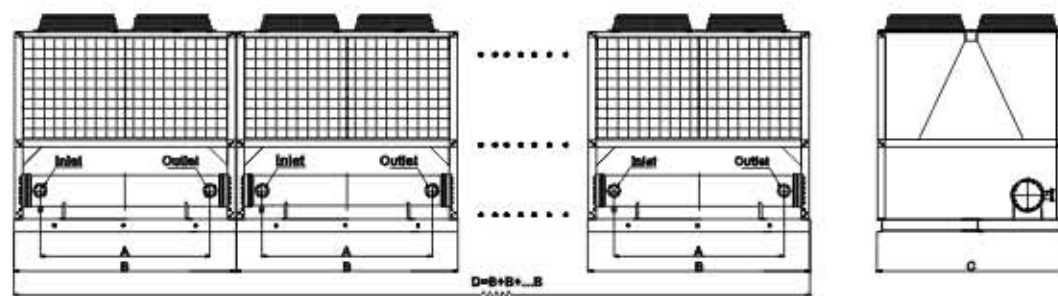

# Installation

## Installation notes

1. There should be more than 1.5m space for service use, and it should be 2.0m preserved between two modules.
2. The machine should be installed in area with good ventilation.
3. If the machine is installed indoor, the room height should be maintained more than 3.0m.
4. The machine should be installed on solid foundation and take necessary shock-proof measures to avoid vibration.
5. Have to be careful when you hoist the unit, DO take measures to avoid collision.
6. If the machine is installed in an area where it snows in winter, necessary shed should be built to cover the machine and keep it away from the snow, do make sure the shed should not affect the ventilation situations, and when the chiller is shut down for a long time, necessary measures should be taken to prevent freezing in the water pipe.
7. Our standard type air-cooled modular chiller is mainly suitable for supplying cool air and warm air to make your living environment more comfortable, if you the chiller is used for process purpose, please contract us for special order.
8. The evaporator (water side heat exchanger) of our air cooled chillers is dry type heat exchanger, it is not suitable for using in open water cycle system. To avoid possible damage to the evaporator due to polluted water, please contact us if your project has such possibilities.

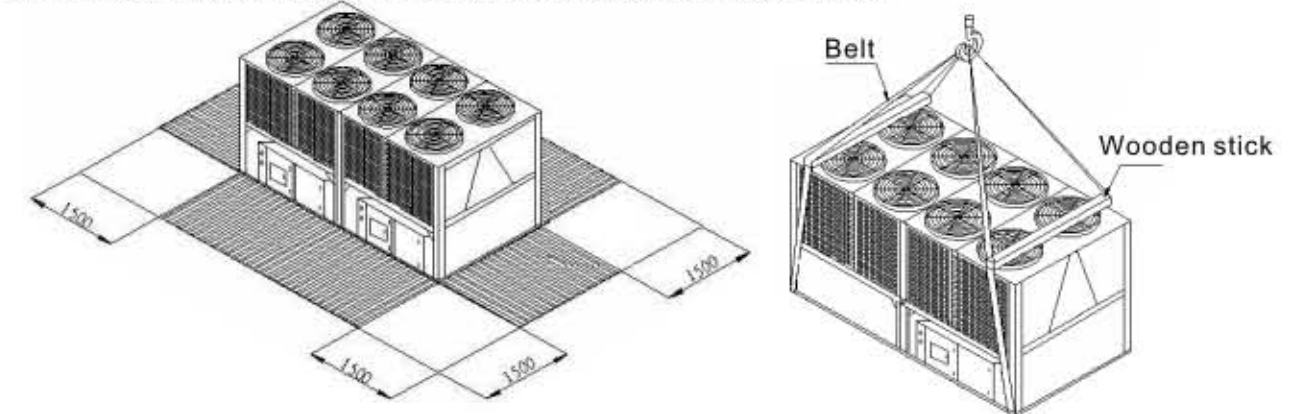

## Installation Foundation Indication Figure

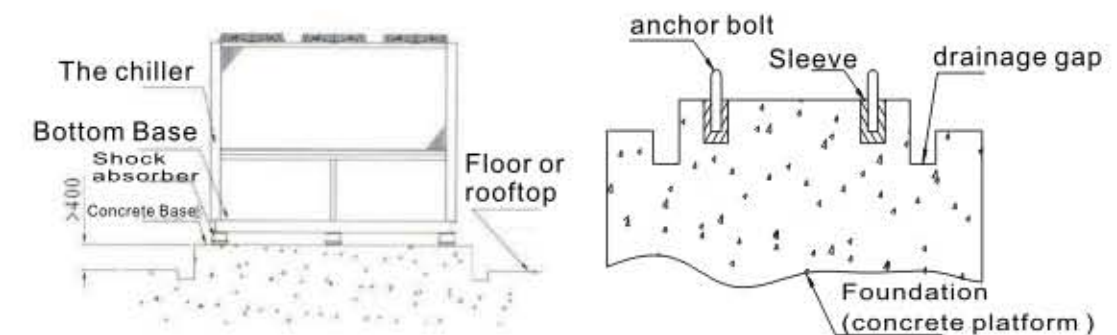

- a) When the machine is installed, you must consider the conformation of foundation whether it is strong enough, and pay more attention to how to reduce the noise. It is better to discuss with the building designer before install it.
- b) To make the equipment operate quietly, avoid shocking or making noise, you should separate the machine base from foundation interface with shock absorber. And to pay attention to keep it level when it is installed, if it is necessary, you can install shock-proof cushion.



## Screw Compressors Series

### Module Combination Water Piping Indication Figure

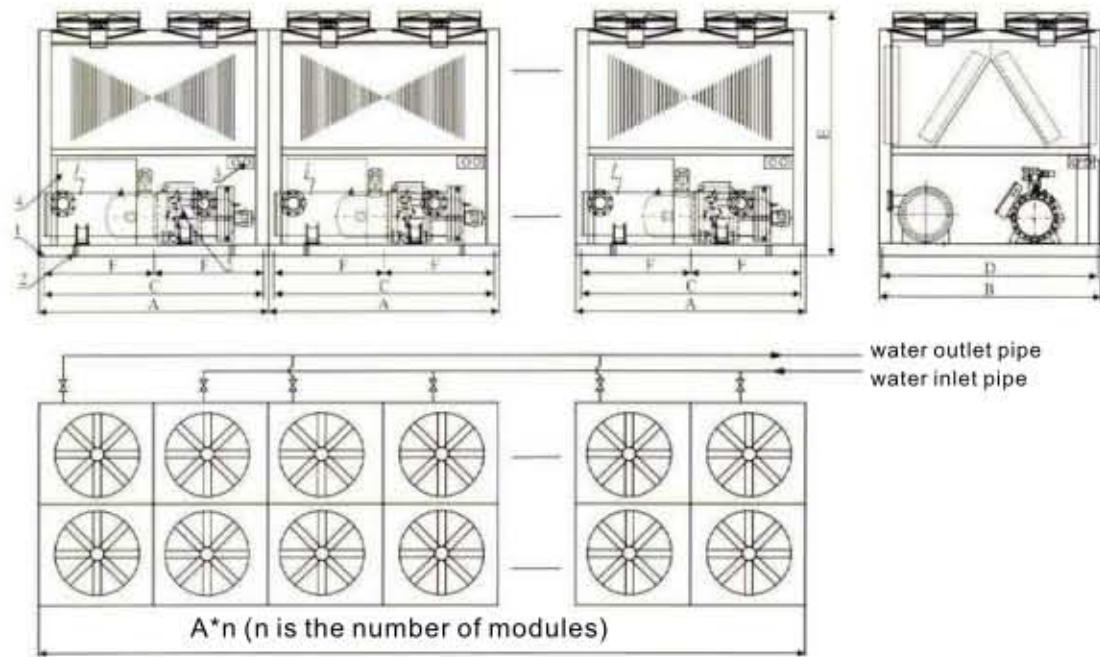

1. Anchor hole 2. Hoisting hole 3. Surface Board 4. Electrical Box 5. Compressor

#### Remark:

1. You can combine random modules together to get the intergrated combination working group with the required cooling capacity, N is the module quantity, you can choose three basic models (160/200/240 KW module) to combine, the total length is the plus of each module length you chose.
2. The outlet and inlet water pipe of machine are connected and installed on the project site, and the way of connection is shown as above figure, the project use components or accessories, for example, the pump accessories ,the soft joints, the water flow switch, check valves, strainers, water pipe, expansion tank and so on, the end user should prepare separately in advance before the installation.

### Water System Piping Diagram

1. Pump must be set at the water inlet. Expansion water tank must be at pump inlet.
2. If the machine is installed in low outdoor temperature environment, or it is idle for a long time(months), it is possible the water pipe shall freeze, so when the water pipe was installed and designed, the anti-freeze function should be taken into consideration to avoid damage to the chiller.
3. When the machine was turned off for a long time (months) in the winter, in order to prevent the pipeline from being frozen, it is better to discharge all the water in the pipeline.
4. There must be equipments for preventing the pipeline being frozen so that the operation efficiency would not be affected .
5. The strainer should be installed in the pump inlet to avoid sundries to come into water side heat exchanger.
6. If the machine is installed in an area where the water quality is poor, the water must be purged again before it enters into the water system to avoid damage to the heat exchanger.

7. To improve the operation efficiency of water system, the vent valve must be installed in the pipeline where it is easy to gather air.
8. To ensure the operation efficiency of machine, the pipeline needs to be cleaned after working, to avoid keeping sundries in the pipeline.
9. When the machine is installed, grounding engineering should be done to prevent electric leakage accident
10. The water flow switches must be installed in the pipeline, and it must be interlocked with the electric control circuit system of the machine
11. After long power off status or the power supply was cut off for more than two hours in winter or the machine is shut down for more than 5 hours in summer, DO remember it is strictly forbidden to start the compressor immediately, the refrigeration oil should be heated for two hours first before start the compressor.
12. When the heat pump units are running while the outdoor ambient temperature is below 5°C, to avoid starting high pressure failure due to too low water temperature, three-way valve must be installed for controlling the temperature of inlet water in the water return pipeline.
13. Under cooling mode, the highest temperature of water inlet is 20°C, while under heating mode, the lowest temperature of inlet water is 30°C.
14. When the heat pump unit is operated in winter, in order to maintain the temperature of water when it is turned off at night, the main power supply and the power supply of pump should not be shut down to ensure the anti-freeze function not be shut down.

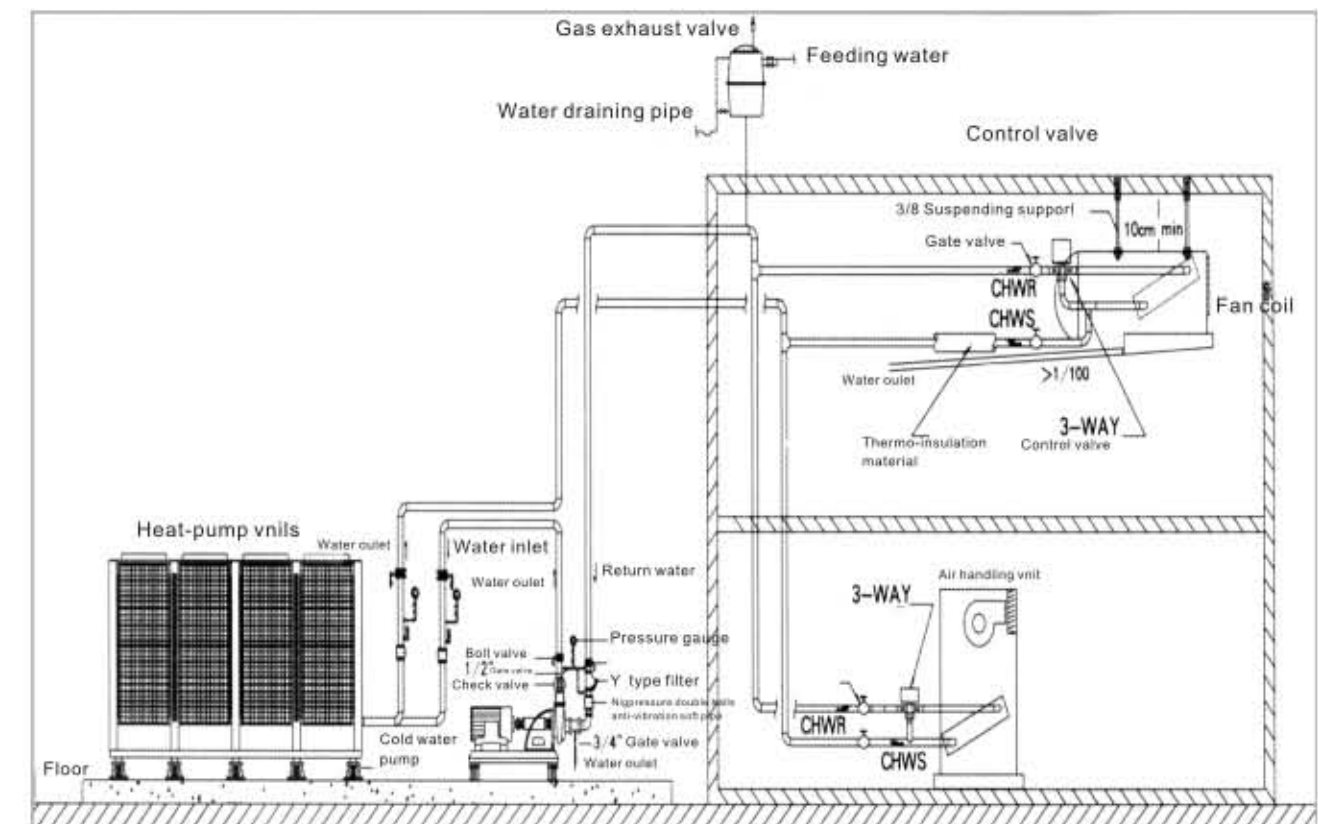

Reference drawing of engineering system (Figure 4)



The configuration table of power supply for user

Model (Single System)	rated current of circuit breaker (A)	Max diameter of line for the wiring board	Diameter of power core
LSBLGRF160TSA	100	22mm <sup>2</sup>	16mm <sup>2</sup>
LSBLGRF200TSA	150	38mm <sup>2</sup>	25mm <sup>2</sup>
LSBLGRF240TSA	150	38mm <sup>2</sup>	35mm <sup>2</sup>

Wire drawing of power supply for single system unit

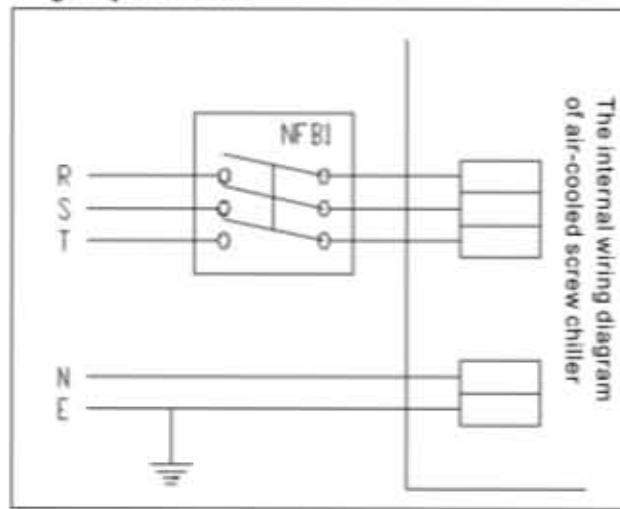

Wire drawing of power supply for double system unit

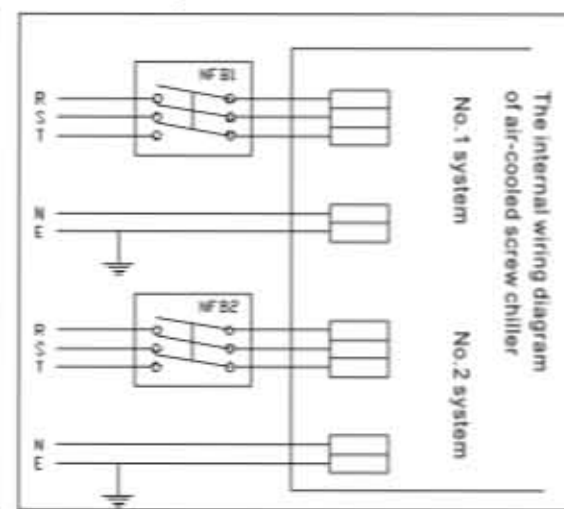

1. The diameter of wiring line in the table is for three phase system wire, it is better to keep the diameter of null line and ground electrode smaller than live wire by 2 levels. (or to consult the standard of general four cores cable).
2. The table is available only when the power supply inlet wire of each pipeline uses one specific PVC pipe. It is forbidden to share the same PVC pipe with other pipelines of power supply. The copper core wire of international BV or BVR or BXR type is used for the wire. The surrounding temperature around the wire is 35 °C. The only factor considered is the safety current load while the factor of voltage drop is not considered in the table.
3. The user should supply the power supply wire for the single compressor unit, for example, the single system unit shown in the figure, and it should be equipped with one breaker, for getting more information, please look at figure 1.
4. The user should supply the power supply wire for the dual compressor unit, for example, the single unit only shown in the figure, also it should be equipped with two breakers, for getting more information, please look at figure 2.
5. If the diameter of wire you chose is bigger than the maximum diameter of connection in main board, please considering to connect the wire between the main power supply wire and the chiller electric box with one moderate diameter wire.

Screw Compressor Series

The cooling /heating performance curve under changeable working conditions

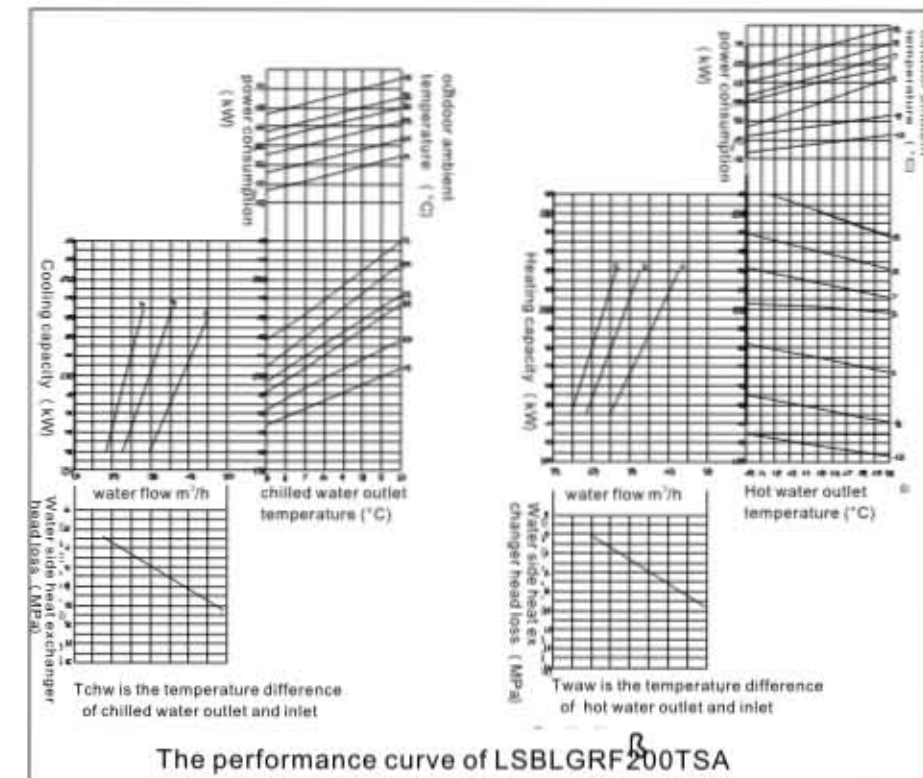
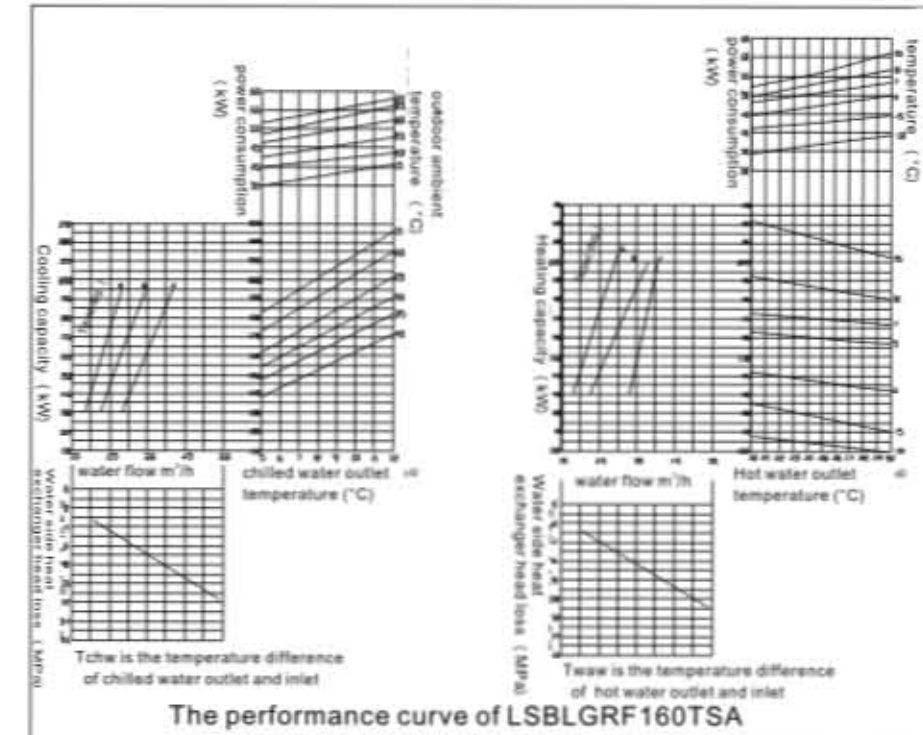



The cooling /heating performance curve under changeable working conditions

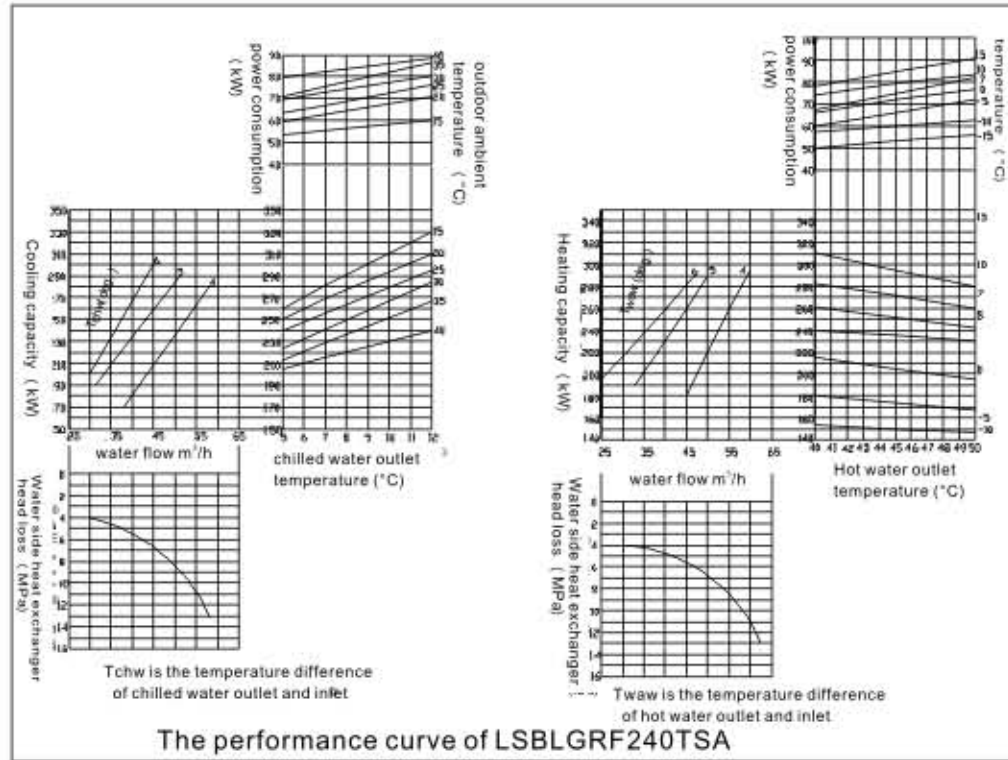

Remark:

The cooling capacity / power input correction coefficient

The normal scaling coefficient is 0.000m<sup>2</sup>C /kW in the ex-factory units, and the maximum scaling coefficient allowed is 0.086 m<sup>2</sup>C /kW, so when the scaling coefficient is over the maximum, the water side heat exchanger should be cleaned.

The scaling coefficient ( m <sup>2</sup> C /kW)	Cooling capacity correction coefficient	Power input correction coefficient
≤0.017	1.045	0.974
0.044	1.022	0.986
0.086	1.000	1.000
0.132	0.980	1.013

The correction coefficient of altitude

Altitude (m above the sea level)	0	300	600	1200	1500	1800
Atmospheric Pressure (bar)	1.013	0.977	0.942	0.875	0.843	0.812
Cooling capacity correction coefficient	1.000	0.993	0.986	0.973	0.967	0.960
Power input correction coefficient	1.000	1.005	1.009	1.021	1.026	1.031

Screw Compressor Series

Auxiliary Electric heater

Working Principle

In winter, when the outdoor ambient temperature goes down, the evaporation temperature of the heat pump chiller will also go down, in consequence, the heating capacity and the EER will also go down. On the contrary, the heat load of the area is increasing, namely symmetrical equilibrium exists between the heating capacity and the room heat load. Right at the equilibrium point, the heat load equals to the heating capacity. When the outdoor temperature is below the equilibrium point temperature, the room heat load will exceed the heating capacity. In order to make the heating capacity to be equal to the heat load again, the auxiliary should be take into consideration to achieve the equilibrium point.

Function

Thus, auxiliary electric heaters are employed by our company, which can be interlock controlled by the chiller microcomputer controller, run safely and stably , the functions are as followings:

- 1.Help to compensate the capacity drop due to low ambient temperature to make the real heating capacity to be equal with the nominal required heating capacity.
- 2.Due to low temperature of the cycling water in the water system, the compressors would face the problem to be started, the auxiliary electric heaters can help to pre-heat the water in advance and free the compressor from the bad working conditions.
- 3.In winter, if the coil surface temperature is below 0°C, there would be frost naturally, and the heat exchanging efficiency would be lower down, even worse, if the frost layer is thick, the system low pressure would be over low, both the motor and the oil would be overheated ,the compressor would be under danger of being damaged. Thus defrost is necessary, auxiliary heater would work to compensate the heat loss during the defrost process and keep the water temperature relatively stable so as to keep the room temperature stable.
- 4.In winter during the nights, when the chiller is shut down, the water system may face the problem of being frozen and the pipe would be broken then, monitoring by the microcomputer, the auxiliary heater would start to work to heat and maintain the water in normal range to avoid the water system from being frozen.

Choose the Model

Usually how to choose the heat pump model depends on the cooling load in summer. When it is in winter, the chiller runs in heating mode, the real heating capacity should be calculated comprehensively according to whole room heating load and the performance parameters of the chiller itself.

Taking LSBLGRF320T2A as an example (water outlet 45°C), the lower temperature outside goes, the lower heating capacity will be, its change is shown in the X curve one of figure. But the heated load will go up in the room, suppose its change is shown in the curve 1 in the figure below , and curve 2 represents the change of the room heating load, the cross point of curve 1 and 2 is the balance point ,right at the balance point, the heat load equals to the heating capacity. When the outdoor temperature is below the equilibrium point temperature, the room heat load will exceed the heating capacity, and the differential is right the needed heating capacity of the auxiliary electric heater.

Refer to the local winter climatic status to confirm the outdoor ambient temperature.



## Memo

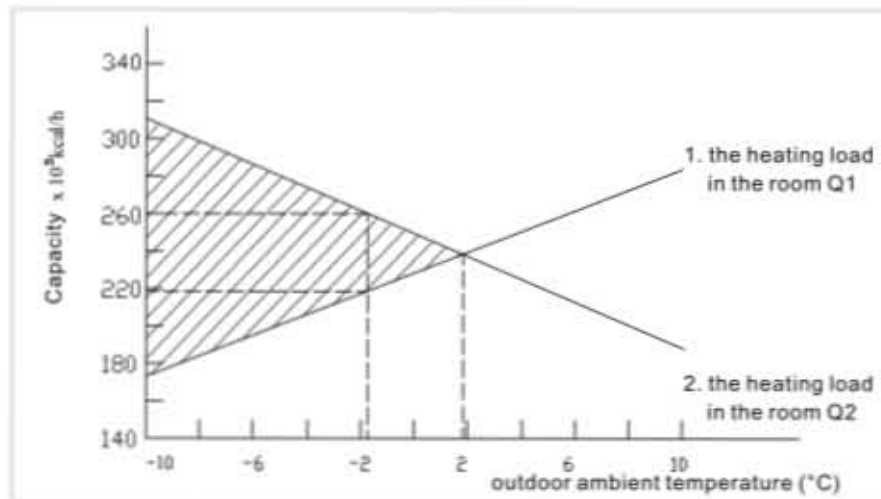

If the outdoor ambient temperature above is -2°C, and the heating load Q2 in the room is 260,000 kcal/h, the nominal heating capacity of machine is 302,000 kcal/h (you can get in the table of performance), and when the outdoor ambient temperature is -2°C, the coefficient of heating capacity is 0.74 in the machine, so the real heating capacity of the chiller would be:

$$302000 \times 0.73 = 220500 \text{ kcal/h}$$

So the needed heating capacity of the auxiliary heater is

$$P = Q2 - Q1 \\ = 260000 - 220500 = 39500 \text{ kcal/h} = 45.9 \text{ kW}$$

If it is not easy or convenient to calculate for you, the table shown below is for your quick reference (the table of power coefficient of auxiliary heater):

Outdoor ambient temperature (°C)	-10	-8	-6	-4	-2	0	2	4
-10		0.21	0.47	0.79	1.19	1.70	2.33	3.15
-8			0.24	0.53	0.89	1.35	1.94	2.70
-6			No Auxiliary Heater	0.26	0.60	1.01	1.55	2.25
-4				0.30	0.68	1.16	1.80	
-2				0.34	0.78	1.35		
0				0.39	0.90			
2				0.45				

Remark:

1. the designed temperature in the room is 20°C (for reference)
2. The power coefficient of auxiliary heater means the required electric heater power kW corresponding to every per unit RT of the chiller.
3. The capacity of auxiliary heater equals to the nominal RT of the chiller\* power coefficient.
4. If you have any questions to choose the model, feel free to contact us.